

OWNER'S GUIDE &

INSTALLATION INSTRUCTIONS

Thru-Hull, Retractable *with* Valve Temperature or Speed Temp Sensor

Models: HT200, ST850

U.S. Patents: 7,110,908; 7,352,171. UK 2 409 527

02/01/11

17-422-01 rev. 04

Follow the precautions below for optimal product performance and to reduce the risk of property damage, personal injury, and/or death.

WARNING: Always wear safety goggles and a dust mask when installing.

WARNING: The valve is not a watertight seal! Always use the insert or the blanking plug secured with the safety wire for a watertight seal.

WARNING: The O-rings must be intact and well lubricated to make a watertight seal.

WARNING: Always attach the safety wire to prevent the sensor insert or blanking plug from backing out in the unlikely event that the cap nut fails or is screwed on incorrectly.

WARNING: Immediately check for leaks when the boat is placed in the water. Do not leave the boat unchecked for more than three hours. Even a small leak may allow considerable water to accumulate.

WARNING: Stainless steel housing in a metal hull—Be sure the washer contacts the hull. Do not tighten the hull nut with the washer against the isolation bushing as the housing will not be firmly installed.

CAUTION: Never install a metal housing in a vessel with a positive ground system.

CAUTION: Never use a fairing with a plastic housing; the protruding sensor would be vulnerable to damage from impact.

CAUTION: Never pull, carry, or hold the sensor by its cable; this may sever internal connections.

CAUTION: Never use solvents. Cleaners, fuel, sealants, paint, and other products may contain strong solvents, such as acetone, which attack many plastics, greatly reducing their strength.

CAUTION: A stainless steel housing must be isolated from a metal hull to prevent electrolytic corrosion.

IMPORTANT: Please read the instructions completely before proceeding with the installation. These instructions supersede any other instructions in your instrument manual if they differ.

Pretest

Connect the sensor to the instrument. Check for the approximate air temperature. If it has a paddlewheel, spin it and check for a speed reading. If there is no reading(s) or it is inaccurate, check the connections and try again. If there is still a problem, return the product to the place of purchase.

Record the information found on the cable tag for future reference.

Part No. _____ Date _____

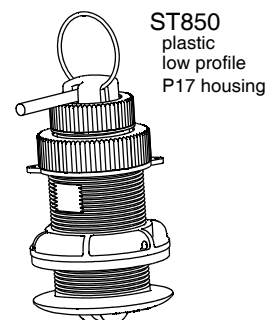
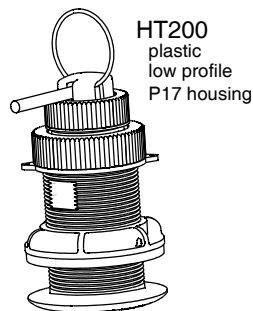

Applications

- **Plastic** housing recommended for fiberglass or metal hulls only. *Never* install a plastic housing in a wood hull since swelling of the wood may overstress the plastic causing a fracture.
- **Bronze** housing recommended for fiberglass or wood hull only. *Never* mount a bronze housing in a metal hull because electrolytic corrosion will occur.
- **Stainless steel** housing compatible with all hull materials. Recommended for aluminum hulls to prevent electrolytic corrosion *provided the stainless steel housing is isolated from the metal hull.*

Tools & Materials

Safety goggles
Dust mask
Water-based anti-fouling paint (**mandatory in salt water**)
Electric drill with 10mm (3/8") or larger chuck capacity
Drill bit 3mm or 1/8"
Hole saw: 51mm or 2" (plastic or metal housing in non-metal hull)
57mm or 2-1/4" (stainless steel housing in a metal hull)
Countersink tool (installing a flush housing)
Sandpaper
Mild household detergent or weak solvent (such as alcohol)
File (installation in a metal hull)
Marine sealant (suitable for below waterline)
Slip-joint pliers (installing a metal housing)
Grommet(s) (some installations)
Cable ties
Installation in a cored fiberglass hull (see page 4)
Hole saw for hull interior 60mm or 2-3/8"
Fiberglass cloth and resin
or Cylinder, wax, tape, and casting epoxy

Mounting Location

CAUTION: Do not mount in an area of turbulence or bubbles near water intake or discharge openings; or behind strakes, fittings or hull irregularities.

CAUTION: Never mount the speed sensor directly ahead of a depth transducer, since turbulence generated by the paddlewheel's rotation will adversely affect the transducer's performance, especially at high speeds. Mount side by side.

Choose an accessible spot inside the vessel. Allow a minimum of 280mm (11") of headroom for the height of the housing, tightening the nuts, and removing the insert.

HT200—The sensor must be in contact with the water at all times.

ST850—Turbulence-free water must flow over the paddlewheel at all boat speeds.

- **Displacement hull powerboats**—Locate amidships near the centerline.
- **Planing hull powerboats**—Mount well aft to ensure the sensor is in contact with the water at high speeds.
- **Fin keel sailboats**—Mount on or near the centerline and forward of the fin keel 300–600mm (1–2').
- **Full keel sailboats**—Locate amidships and away from the keel at the point of minimum deadrise.

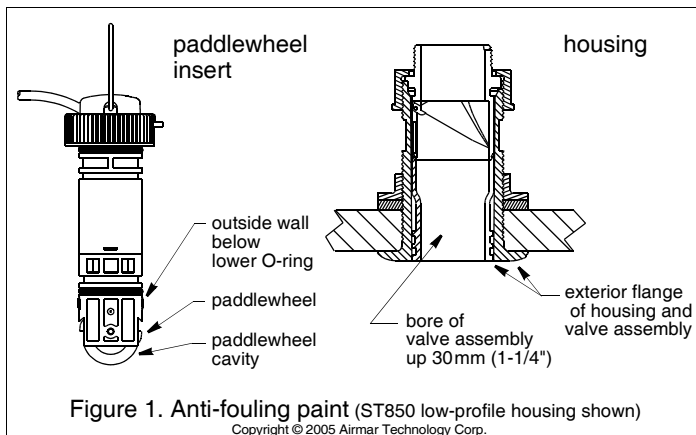

Figure 1. Anti-fouling paint (ST850 low-profile housing shown)

Copyright © 2005 Airmar Technology Corp.

Anti-fouling Paint

Aquatic growth can accumulate rapidly on the sensor's surface reducing performance within weeks. Surfaces exposed to salt water must be coated with anti-fouling paint. Use water-based anti-fouling paint only. Never use ketone-based paint, since ketones can attack many plastics possibly damaging the sensor.

It is easier to apply anti-fouling paint before installing the sensor, but allow sufficient drying time. Reapply paint every 6 months or at the beginning of each boating season. Paint the following surfaces (see Figure 1):

- Bore of the valve assembly up 30mm (1-1/4")
- Exterior flange of the housing and valve assembly
- Blanking plug below the lower O-ring including the exposed end
- Temperature insert below the lower O-ring including the exposed end
- Paddlewheel insert:
 - Outside wall below the lower O-ring
 - Paddlewheel cavity
 - Paddlewheel

Installation

Hole Drilling

Cored fiberglass hull—Follow separate instructions on page 4.

1. Drill a 3mm or 1/8" pilot hole from inside the hull. If there is a rib, strut or other hull irregularity near the selected mounting location, drill from the outside.
2. Using the appropriate size hole saw, cut a hole perpendicular to the hull from outside the boat.

Flush housing—Use a countersink tool to create a "seat" in the hull.

3. Sand and clean the area around the hole, inside and outside, to ensure that the sealant will adhere properly to the hull. If there is any petroleum residue inside the hull, remove it with either mild household detergent or a weak solvent (alcohol) before sanding.

Metal hull—Remove all burrs with a file and sandpaper.

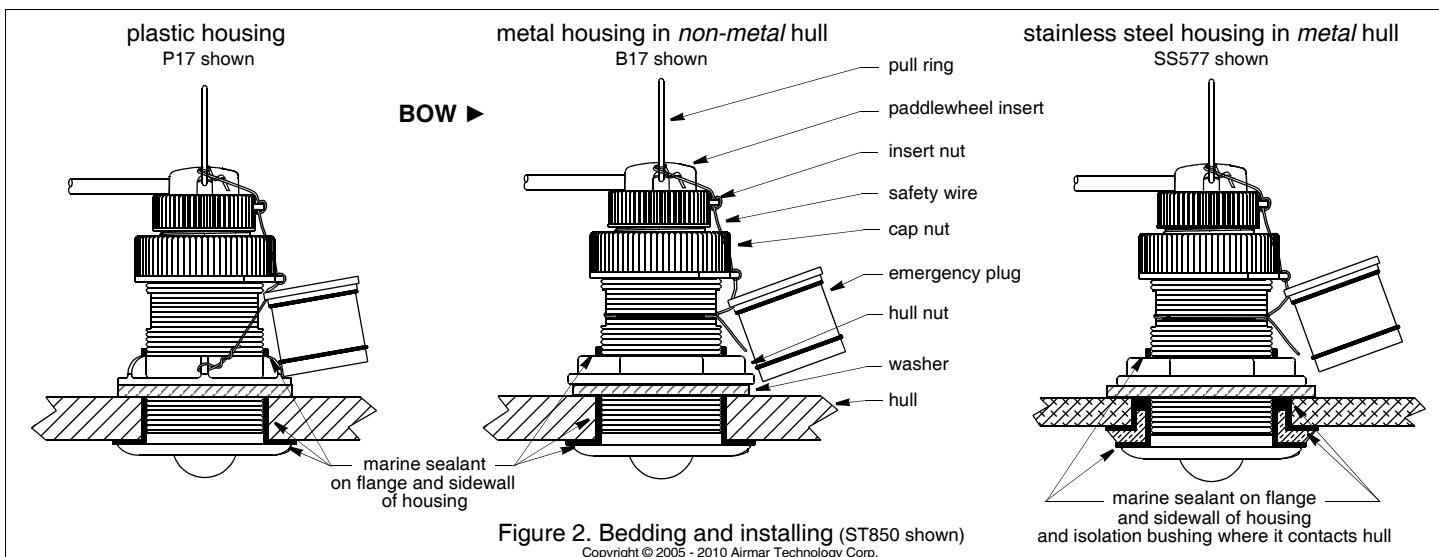

Figure 2. Bedding and installing (ST850 shown)

Copyright © 2005 - 2010 Airmar Technology Corp.

Bedding

CAUTION: Be sure the surfaces to be bedded are clean and dry.

Apply a 2mm (1/16") thick layer of marine sealant around the flange of the housing that will contact the hull and up the sidewall of the housing (see Figure 2). The sealant must extend 6mm (1/4") higher than the combined thickness of the hull, washer, and hull nut. This will ensure there is sealant in the threads to seal the hull and to hold the hull nut securely in place.

Stainless steel housing in a metal hull—The stainless steel housing must be isolated from the metal hull to prevent electrolytic corrosion. Slide the isolation bushing onto the housing. Apply additional sealant to the surfaces of the bushing that will contact the hull, filling any cavities in and around the bushing.

Installing

CAUTION: If your sensor came with a connector, do not remove it to ease cable routing. If the cable must be cut and spliced, use Airmar's splash-proof Junction Box No. 33-035 and follow the instructions provided. Removing the waterproof connector or cutting the cable, except when using a watertight junction box, will void the sensor's warranty.

1. From outside the hull, push the housing into the mounting hole using a twisting motion to squeeze out excess sealant (see Figure 2). Align the arrow on the flange of the housing to point forward toward the bow. If the sensor is not installed on the centerline, angle the housing slightly toward the centerline to align it with the water flow.

2. From inside the hull, slide the washer onto the housing.

Stainless steel housing in a metal hull—Be sure the washer contacts the hull. Do not tighten the hull nut with the washer against the isolation bushing as the housing will not be firmly installed. If necessary, sand the isolation bushing until the washer rests against the hull.

3. Screw the hull nut in place being sure the notch on the upper rim of the housing and the corresponding arrow on the flange are still positioned forward toward the bow.

Plastic housing—Do not clamp tightly on the wrenching flats, possibly causing the housing to fracture.

Plastic hull nut—Hand tighten only. Do not over tighten.

Metal hull nut—Tighten with slip-joint pliers.

Cored fiberglass hull—Do not over tighten, crushing the hull.

Wood hull—Allow the wood to swell before tightening the hull nut.

4. Remove any excess marine sealant on the outside of the hull to ensure smooth water flow over the sensor.
5. After the marine sealant cures, inspect the O-rings on the valve assembly (replace if necessary) and lubricate them with the silicone lubricant supplied (see Figure 3). The O-rings must be intact and well lubricated to make a watertight seal.
6. Slide the valve assembly into the housing. Seat it into place with a pushing twisting motion until the key fits into the notch. Screw the CAP nut in place and hand tighten only. Do not over tighten.

- Slide the insert nut along the cable until it rests on the top of the insert. Attach the pull ring to the insert, capturing the insert nut.
- Inspect the O-rings on the paddlewheel/temperature insert (replace if necessary) and lubricate them with the silicone lubricant supplied.
- Slide the insert into the housing. Seat it into place with a pushing twisting motion until the key fits into the notch. Be careful not to rotate the housing and disturb the sealant. Screw the INSERT nut in place and **hand tighten** only. Do not over tighten.

ST850—The paddlewheel insert must have the arrow on the top pointing forward toward the bow. (The cable exit points away from the bow.)

- Always attach the safety wire to prevent the insert from backing out in the unlikely event that the insert nut and/or cap nut fails or is screwed on incorrectly (see Figure 2).

Plastic housing—Attach the safety wire securely to one eye in the hull nut. Thread the short emergency plug onto the wire. Keeping the wire taut throughout, lead the wire in a counterclockwise direction and thread it through one eye in the CAP nut. Thread the wire through the eye a second time. Then lead the wire in a counterclockwise direction and thread it through the eye in the INSERT nut. Thread the wire through the eye a second time. Loop the wire through the pull ring and twist the wire securely to itself.

Metal housing—Wrap one end of the safety wire tightly around the housing and twist it together with the long end. Thread the short emergency plug onto the wire. Keeping the wire taut throughout, lead the wire straight up and through one eye in the CAP nut. Thread the wire through the eye a second time. Lead the wire in a counterclockwise direction and thread it through the eye in the INSERT nut. Thread the wire through the eye a second time. Loop the wire through the pull ring and twist the wire securely to itself.

- Route the cable to the instrument being careful not to tear the cable jacket when passing it through the bulkhead(s) and other parts of the boat. Use grommet(s) to prevent chafing. To reduce electrical interference, separate the sensor cable from other electrical wiring and the engine. Coil any excess cable and secure it in place with cable ties to prevent damage. Refer to the instrument owner's manual to connect the sensor to the instrument.

Retrofit Into ST650 Housing

The HT200 and ST850 insert can be installed in a new or existing ST650 housing. **However, the ST650 valve assembly inside the housing must be replaced with the HT200/ST850 valve assembly**, so the new insert will fit. To replace the valve assembly, follow the instructions "Servicing the Valve Assembly" on page 4.

Checking for Leaks

When the boat is placed in the water, **immediately** check around the thru-hull sensor for leaks. Note that very small leaks may not be readily observed. *Do not leave the boat in the water for more than 3 hours before checking it again.* If there is a small leak, there may be considerable bilge water accumulation after 24 hours. If a leak is observed, repeat "Bedding" and "Installing" **immediately** (see page 2).

Installation in a Cored Fiberglass Hull

The core (wood or foam) must be cut and sealed carefully. The core must be protected from water seepage, and the hull must be reinforced to prevent it from crushing under the hull nut allowing the housing to become loose.

CAUTION: Completely seal the hull to prevent water seepage into the core.

- Drill a 3mm or 1/8" pilot hole from inside the hull. If there is a rib, strut, or other hull irregularity near the selected mounting location, drill from the outside. (If the hole is drilled in the wrong location, drill a second hole in a better location. Apply masking tape to the outside of the hull over the incorrect hole and fill it with epoxy.)
- Using the 51 mm or 2" hole saw, cut the hole from outside the hull through the *outer skin* only (see Figure 4).
- From inside the hull, use the 60mm or 2-3/8" hole saw to cut through the *inner skin* and most of the core. The core material can be very soft. Apply only light pressure to the hole saw after cutting through the inner skin to avoid accidentally cutting the *outer skin*.
- Remove the plug of core material so the *inside* of the outer skin and the inner core of the hull are fully exposed. Sand and clean the inner skin, core, and the outer skin around the hole.

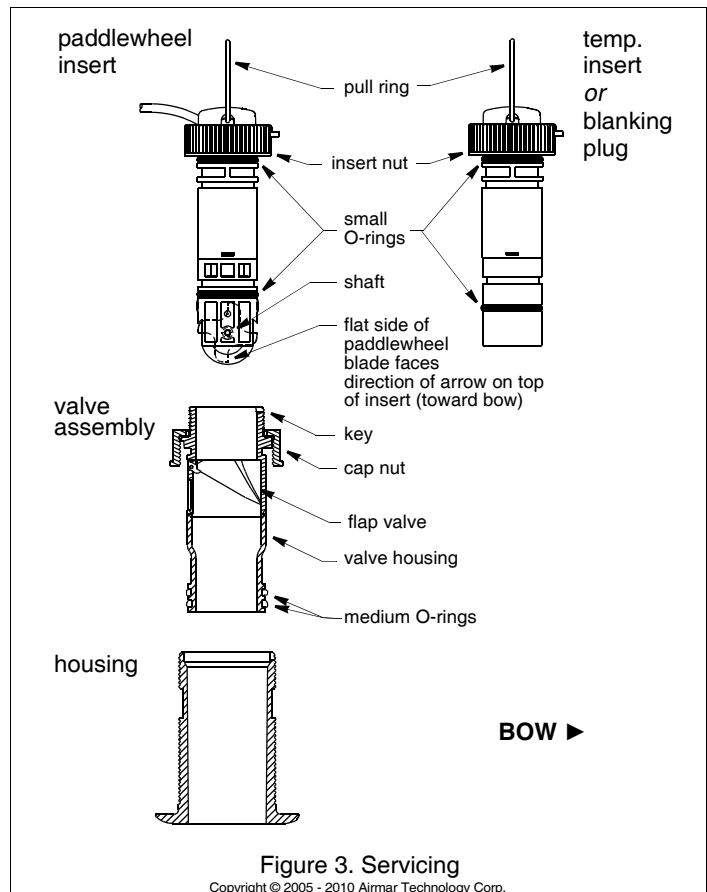

Figure 3. Servicing

Copyright © 2005 - 2010 Airmar Technology Corp.

- If you are skilled with fiberglass, saturate a layer of fiberglass cloth with a suitable resin and lay it inside the hole to seal and strengthen the core. Add layers until the hole is the correct diameter. Alternatively, a hollow or solid cylinder of the correct diameter can be coated with wax and taped in place. Fill the gap between the cylinder and hull with casting epoxy. After the epoxy has set, remove the cylinder.
- Sand and clean the area around the hole, inside and outside, to ensure that the sealant will adhere properly to the hull. If there is any petroleum residue inside the hull, remove it with either mild household detergent or a weak solvent (alcohol) before sanding.
- Proceed with "Bedding" and "Installing" on page 2.

Operation & Maintenance

How the Valve Works

The valve is not a watertight seal! The sensor incorporates a self-closing valve which minimizes the flow of water into the vessel when the paddlewheel/temperature insert is removed. The curved flap valve is activated by both a spring and water pressure. Water pushes the flap valve upward to block the opening, so there is no gush of water into the boat. *Always install the paddlewheel/temperature insert or the long blanking plug secured with the INSERT nut and safety wire for a watertight seal.*

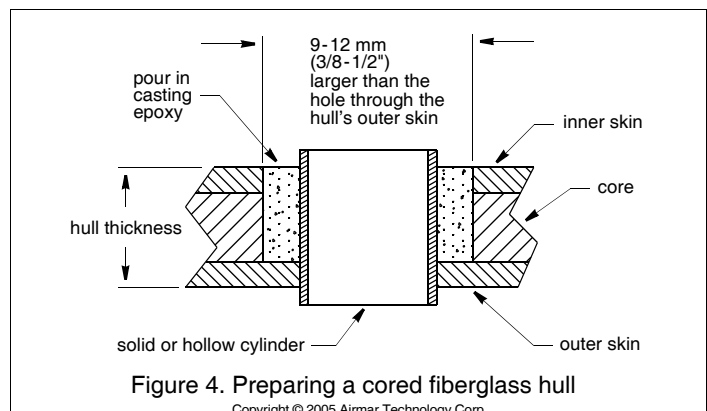

Figure 4. Preparing a cored fiberglass hull

Copyright © 2005 Airmar Technology Corp.

Using the Long Blanking Plug

To protect the paddlewheel/temperature insert, use the *long* blanking plug when the boat will be kept in salt water for more than a week, when the boat will be removed from the water, or when aquatic growth buildup on the insert is suspected due to inaccurate readings from the instrument.

1. Place the INSERT nut on the top of the *long* blanking plug. Attach the pull ring to the plug, capturing the insert nut (see Figure 3).
2. Inspect the O-rings on the *long* blanking plug (replace if necessary) and lubricate them with the silicone lubricant supplied or petroleum jelly (Vaseline®). The O-rings must be intact and well lubricated to make a watertight seal.
3. Remove the paddlewheel/temperature insert from the housing by removing the safety wire from the pull ring and the INSERT nut. Unscrew the INSERT nut (see Figure 2). *Do not remove the CAP nut.*
4. Grasp the pull ring and remove the insert with a slow pulling motion.
NOTE: In the unlikely event that the insert cannot be removed, see "Servicing the Valve Assembly" on page 3.
5. Slide the *long* blanking plug into the housing (see Figure 3). Seat it into place with a pushing twisting motion until the key fits into the notch. Screw the INSERT nut in place and **hand tighten** only. Do not over tighten.
6. Reattach the safety wire to prevent the *long* blanking plug from backing out in the unlikely event that the insert nut and/or cap nut fails or is screwed on incorrectly (see Figure 2).

Servicing the Valve Assembly

Should the valve fail, remove it for servicing. Order a replacement Paddlewheel & Valve Kit No. 33-536-01.

WARNING: When the valve assembly is removed, always insert the short emergency plug secured with the CAP nut and safety wire for a watertight seal.

WARNING: If the insert is caught in the valve assembly trapping the CAP nut, **temporarily** hold the short emergency plug in place with the safety wire. Then, separate the insert from the valve assembly. If they cannot be separated and the sensor must be left unattended, remove the pull ring, unscrew the insert nut, and unscrew the cap nut. Cut the cable a minimum of 1 m (3') from the insert to free the CAP nut. Later, splice the cable using Airmar's splash-proof Junction Box No. 33-035.

1. Remove the short emergency plug from the safety wire (see Figure 2).
2. Inspect the O-ring (replace if necessary) and lubricate it with silicone lubricant or petroleum jelly (Vaseline®) (see Figure 3). The O-ring must be intact and well lubricated to make a watertight seal.
3. Unscrew the CAP nut. With the short emergency plug ready in one hand, remove the paddlewheel/temperature insert and valve assembly as one unit by pulling upward on the pull ring. Rapidly insert the short emergency plug to minimize the flow of water into the boat.
Note: The short emergency plug is not secure until the CAP nut is in place.
4. To free the CAP nut, remove the paddlewheel/temperature insert from the valve assembly by unscrewing the INSERT nut. Grasp the insert by the pull ring and pull slowly upward.
5. Secure the short emergency plug with the cap nut. **Hand tighten** only. Do not over tighten. Reattach the safety wire (see Figure 2).
6. Clean, repair, or replace the valve assembly, so the flap valve moves freely and seats against the valve housing (see Figure 3).
7. To reinstall the valve assembly and paddlewheel/temperature insert, inspect (replace if necessary) and lubricate all of the O-rings with silicone lubricant or petroleum jelly (Vaseline®). The O-rings must be intact and well lubricated to form a watertight seal.
8. Remove the safety wire from the CAP nut and unscrew it. With the valve assembly ready in one hand, remove the short emergency plug. Rapidly slide the valve assembly into the housing. Seat it into place with a pushing twisting motion until the key fits into the notch. Screw the CAP nut in place **hand tighten** only. Do not over tighten.
9. Reinstall the insert. Be sure the paddlewheel insert has the arrow on the top pointing forward toward the bow. (The cable exit points away from the

bow.) Seat it into place with a pushing twisting motion until the key fits into the notch. Screw the INSERT nut in place and **hand tighten** only. Do not over tighten.

10. Attach the safety wire to the short emergency plug, the cap nut, the insert nut, and the pull ring to prevent the insert from backing out in the unlikely event that the insert nut and/or cap nut fails or is screwed on incorrectly (see Figure 2).

ST850: Servicing the Paddlewheel Insert

Aquatic growth can impede or freeze the paddlewheel's rotation and must be removed. Clean the sensor with mild household detergent and a Scotch-Brite® scour pad. If fouling is severe, push out the paddlewheel shaft using a spare shaft or a 4D finish nail with a flattened point. Then, lightly wet sand the paddlewheel with fine grade wet/dry paper.

The water lubricated paddlewheel bearings have a life of up to 5 years on low-speed boats [less than 10kn (11MPH)] and 1 year on high-speed vessels. Paddlewheels can fracture and shafts can bend due to impact with water borne objects and mishandling in boat yards. O-rings must be free of abrasions and cuts to ensure a watertight seal. Order a replacement Paddlewheel, Shaft & O-ring Kit No. 33-113.

1. Using the new paddlewheel shaft, push the old shaft out about 6mm (1/4"). With pliers, remove the old shaft (see Figure 3).
2. Place the new paddlewheel in the cavity with the flat side of the blade facing the same direction as the arrow on the top of the insert.
3. Tap the new shaft into place until the ends are flush with the insert.
4. Install two of the small O-rings.
5. The remaining two small O-rings are for the *long* blanking plug.
6. To reinstall the paddlewheel insert, see "Installing" on page 2 and follow steps 8 through 10.

Winterizing

After the boat has been hauled for winter storage, remove the blanking plug to let the water drain away before reinserting it. This will prevent any water from freezing around the blanking plug and possibly cracking it.

Replacement Sensor & Parts

The information needed to order a replacement Airmar sensor is printed on the cable tag. Do not remove this tag. When ordering, specify the part number and date. For convenient reference, record this information at the top of page one.

Lost, broken, and worn parts should be replaced immediately. If you have purchased a plastic housing and have a wood hull or desire greater strength, purchase an Airmar metal housing. If you have a low profile housing and prefer a flush housing, see the following list.

Part	Airmar Part Number
Blanking Plug	33-522-01
Paddlewheel, Shaft, O-ring Kit	33-113
Valve & Paddlewheel Kit	33-536-01
Cap Nut	04-234-1 (plastic)
	02-131-01 (bronze)
Hull Nut	04-004 (plastic)
	02-030 (bronze)
	02-570-01 (stainless steel)
Isolation Bushing	04-186-1
Housing, Hull Nut & Washer	33-100 (bronze, low profile, B17)
	33-224-01 (bronze, flush, B21)
	33-217 (plastic, flush, P217)
	33-092-01 (plastic, flush, P314)
	33-495-01 (stainless steel, low profile, SS577)

Obtain parts from your instrument manufacturer or marine dealer.

Gemeco (USA)	Tel: 803.693.0777
	Fax: 803.693.0477
	email: sales@gemeco.com
Airmar EMEA (Europe, Middle East, Africa)	Tel: +33.(0)2.23.52.06.48
	Fax: +33.(0)2.23.52.06.49
	email: sales@airmar-emea.com

NMEA 2000 Specification

HT200 Load Equivalency Number (LEN).....1

AIRMAR®
TECHNOLOGY CORPORATION

35 Meadowbrook Drive, Milford, New Hampshire 03055-4613, USA
www.airmar.com